

HTC-36S WIDE DYNAMIC CCD CAMERA

Main Features

- 1/3" Color Wide Dynamic Double Speed CCD
- Super high Res up to 540 TVL
- WD range up to 128X
- Anti color rolling
- Day/Night Function
- Dual Power DC 12V/AC 24V
- Line Lock Available



Interface

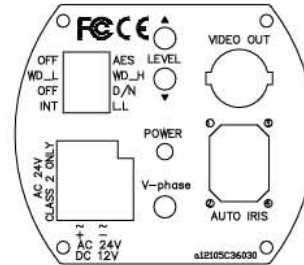
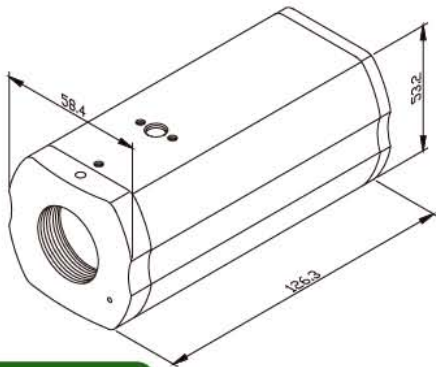

Specifications

| ITEM | HTC-36S | |
|-----------------------|--|-----------|
| PICK UP DEVICE | 1/3"Vertical Double Density Interline CCD Image Sensor | |
| SYSTEM | NTSC | PAL |
| PICTURE ELEMENTS H*V | 768 * 494 | 752 * 582 |
| H. SYNC. FREQUENCY | 15.734KHz | 15.625KHz |
| V. SYNC. FREQUENCY | 59.94Hz | 50Hz |
| HORIZONTAL RESOLUTION | 540 TV Lines | |
| SCANNING SYSTEM | 2:1 Interlace | |
| SENSITIVITY | 0.05 Lux F=1.2 | |
| SYNCHRONIZATION | Internal / Line lock | |
| S/N RATIO | More Than 50 dB (AGC Off) | |
| WIDE DYNAMIC RANGE | 128X | |
| WIDE DYNAMIC FUNCTION | LO / Hi Switchable | |
| ELECTRONIC SHUTTER | On / Off Switchable ; Range 1/50(1/60) Up to 1/100,000 sec | |
| GAIN CONTROL | Auto | |
| INT / LL FUNCTION | Internal / Line lock Switchable | |
| LENS | CS Mount | |
| DAY/NIGHT FUNCTION | ON/OFF Switchable | |
| IR CUT FILTER CHANGE | Optional | |
| VIDEO OUTPUT | 1 Vpp, 75 Ohms | |
| POWER SUPPLY | Dual Power DC 12V / AC 24V | |
| POWER CONSUMPTION | 230mA at DC 12V, 3W at AC 24V | |
| DIMENSIONS (W*H*D) | 58.4*53.2*126.3 mm | |
| WEIGHT | 290 g | |
| STORAGE TEMPERATURE | -30 To + 60 °C | |
| OPERATING TEMPERATURE | -10 To + 45 °C | |



* Due to continuous product enhancement, Sin Chew Alarm reserves the right to change / modify specification without prior notice.